



# Plant Archives

Journal homepage: <http://www.plantarchives.org>

DOI Url : <https://doi.org/10.51470/PLANTARCHIVES.2026.v26.no.1.251>

## MEAN PERFORMANCE OF COWPEA GENOTYPES (*VIGNA UNGUICULATA* L. WALP) AND PATH ANALYSIS OF VARIOUS TRAITS

Mahendra Kumar Seemar<sup>1\*</sup>, Champa Lal Khatik<sup>1</sup>, Hanuman Singh Jatav<sup>2</sup>, Kailash Chandra<sup>3</sup> and Sarita Choudhary<sup>1</sup>

<sup>1</sup>Department of Genetics and Plant Breeding, College of Agriculture (SKNAU) Fatehpur-Shekhawati, Sikar, Rajasthan-332301, India

<sup>2</sup>Department of Soil Science and Agricultural Chemistry, College of Agriculture (SKNAU) Fatehpur-Shekhawati, Sikar, Rajasthan-332301, India

<sup>3</sup>Department of Genetics and Plant Breeding, SKNCOA, (SKNAU), Jobner -303329, Rajasthan, India

\*Corresponding author E-mail: mahendrakhatushyamji@gmail.com

(Date of Receiving : 12-01-2026; Date of Revision : 08-03-2026; Date of Acceptance : 28-03-2026)

### ABSTRACT

A field experiment was carried out to estimate the mean performance and path analysis for yield and yield attributing traits among eighteen genotypes of cowpea [*Vigna unguiculata* (L.) Walp] in a RBD with three replications at Research Farm, College of Agriculture, Fatehpur-Shekhawati, Sikar during Kharif 2024. The analysis of variance in genotypes for all the character revealed the significant genetic variability. At genotypic level the maximum positive direct effect of pod length (1.8451) was recorded on grain yield per plant. Furthermore, number branches per plant (1.7082), number pods per cluster (0.3877), days to maturity (0.0930) and plant height (0.0872) also positive correlation with grain yield per plant. At phenotypic level the maximum positive direct effect of number seed per pod (0.5153) was observed on grain yield per plant. Furthermore, plant height (0.3568), days to 50% flowering (0.3209), branches per plant (0.2501), pod per cluster (0.1967) and seed weight (0.0498) was earlier said to be positively correlated with grain yield. So, selection based on this character will result in the high performing superior genotypes of cowpea. Among the genotypes studied, IC-0650821, CPD-305, CF9-1-9, CF1-1-1, CF2-1-2 and CPD-273 were found to be high yielding and may be evaluated in future breeding programme.

**Keywords :** Cowpea, Genotypes, Mean Performance and Path Analysis.

### Introduction

Cowpea [*Vigna unguiculata* (L.) Walp.] a legume crop and it is component of farming systems throughout the tropics and warm sub-tropics regions. Cowpea is a self-pollinated crop and belongs to the family Fabaceae and genus *Vigna* with chromosome number,  $2n = 22$ . Known as snake bean and yard-long bean, these cultivars are farmed for their grain, green pods, and fodder, which are consumed as vegetables. This crop has a reputation for being drought-tolerant; the shadowing effect of its broad, drooping leaves helps to preserve soil and soil moisture. It is also known as the black-eyed pea or southern pea, and it can be used as a vegetable, green manure, feed, fodder,

and food. A nutrient-dense part of the human diet, cowpea seed is also inexpensive animal fodder.

In India, it is a small pulse that is grown primarily in arid and semi-arid areas of parts of Rajasthan, Karnataka, Kerala, Tamil Nadu, Maharashtra, Gujarat, and Punjab, Haryana, Delhi, and west Uttar Pradesh. The area, production and productivity/yield of cowpea in Rajasthan is 50.7 thousand/ha, 23.1 thousand/ha and 4.56 q/ha respectively (Anonymous, 2024). Cowpea is rich in protein (22-24%), carbohydrate (55-66%), Iron (0.005%), calcium (0.08-0.11%) essential amino acids such as lysine, leucien and phenylalanine (Anonymous, 2023a). It may be adapted to various soil types, intercropping systems, and drought tolerance. In many developing nations, it is a significant crop for the

economy. Farmers also receive crucial revenue from the selling of the stems and leaves as animal feed during the dry season.

Path coefficient analysis helps in partitioning the correlation into direct and indirect effects of different components on yield (Ahmad, 2013). The path efficient analysis applied for statistical analysis of cause and effect, which gives a critical evaluation of the underlying factors influencing the correlation. As a result, correlation studies in conjunction with path coefficient analysis are an effective method for examining character associations and how they ultimately affect yield, which aids in the selection process. (Bizeti *et al.*, 2004). Path coefficient analysis provides insights into the size and direction of both direct and indirect impacts on yield and its contributing components, a detail not captured by correlation. Additionally, it establishes the cause-and-effect relationship, proving beneficial in decomposing the correlation into its direct and indirect contributions to yield (Chaudhary and Joshi, 2005).

### Materials and Methods

The experiment was conducted during *kharif*, 2024 at Research farm of College of Agriculture, (Sri Karan

Narendra Agriculture University, Jobner) Fatehpur-Shekhawati, Sikar (Rajasthan). It is situated between 27° 57' 04.01" N to 27° 55' 43.59" N latitude and 74° 58' 47.47" E to 74° 59' 45.97" E longitude with an altitude of 321 to 330 meters above mean sea level. The weather data at time of experiment are presented in appendix-I. The experiment was conducted fifteen genotypes with three checks in Randomized Complete Block Design of cowpea crop for estimate genetic variability and correlation analysis. The observation was recorded five randomly selected plant for plant height, branches per plant, pods per cluster, pod per plant, pod length, seeds per pod, seed weight and grain yield per plant except days to 50 % flowering and days to maturity. The ANOVA for Randomized Complete Block Design of experiment were carried out using the method suggested by Panse and Sukhatme (1985). The direct and indirect effect was estimated by using path coefficient as suggested by Wright (1921) and further, elaborates by D

ewey and Lu (1959). The details of the genotypes and checks used in the investigation are presented in table 1: -

**Table 1 :** Details of genotypes and checks used in experiment

Genotypes					Checks
1.CPD-229	4.CPD-273	7.CPD-307	10.IC-0650821	13. CF4-1-4	16.RC-19(C)
2.CPD-260	5.CPD-302	8.CPD-317	11. CF1-1-1	14. CF9-1-9	17.RC-101(C)
3.CPD-269	6.CPD-305	9.CPD-330	12.CF2-1-2	15. CF10-1-10	18. TC-901(C)

**Source:** - Department of Genetics and Plant Breeding, ARS Fatehpur-Shekhawati, Sikar

### Results and Discussions

#### Analysis of Variance

The analysis of variance was highly significant for all characters these are presented in table 2. Analysis of variance for the experiment involving a set of 18 genotypes of cowpea for 10 characters namely days to 50 % flowering, days to maturity, plant height, branches per plant, pods per cluster, pods per plant, pod length, seed per pods, seed weight and grain yield per plant revealed that mean sum of square were highly significant all characters indicating the presence of considerable genetic variation in the experiment material. The significant variation for grain yield and its related traits in cowpea were also observed earlier workers like Singh *et al.* (2022), Hulsure *et al.* (2022) and Kiran *et al.* (2020).

#### Mean Performance

The mean performance of different cowpea was presented in table 3. High yields are the main objective

of all crop improvement programmes. Among 18 genotypes, genotypes namely IC-0650821 (14.00g), CF1-1-1 (13.60g), CPD-307 (13.73g), CPD-317 (13.53g), CPD-260 (13.40g), CPD-269 (13.40g) and CF2-1-2 (13.33g) sustainability displayed higher grain yield per plant. Early days to 50% flowering are desirable character in cowpea the genotype CF9-1-9 (42.67 days), CPD-273 (44.00 days), CPD-305 (44.33 days) and CPD-330 (44.67 days) were showed in early flowering. Early maturity is also a desirable character in cowpea for the genotypes of CF9-1-9 (58.67 days), IC-0650821 (59.67 days), CF1-1-1 (61.67 days) and CF10-1-10 (62.00 days) were found. Highest plant height of genotype like CPD- 305 (59.75 cm), CPD-317 (59.45 cm), CPD-307 (56.62 cm), CPD-302 (54.91 cm) and CPD-273 (53.70 cm) were found. Branches per plant is an important and desirable trait in cowpea for high grain yield per plant, in the current study. Maximum branches per plant was recorded in genotypes IC-065821 (9.53), CF4-1-4 (8.93), CPD-302 (8.27), CPD-229 (7.67) and CF10-1-10 (7.53). Number

Pods per plant also play a vital role for higher yield in any pulse crop, in present investigation maximum number of pods per plant was observed in genotypes IC-0650821 (21.80), CPD-307 (21.27), CF4-1-4 (21), and CF10-1-10 (21.00), CPD-330 (20.67). Pods per cluster is also important trait for higher yield in cowpea in the present study maximum pods per cluster observed in genotypes IC-0650821 (4.00), CF-2-1-2 (3.33), CPD-273 (3.13), CPD-307 (3.07), CF-10-1-10 (2.87) and CPD-305 (2.83). Pod length also plays an important role for higher yield in any pulse crops. The maximum pod length was recorded of genotypes CPD-305 (15.87), TC-901 (15.67), CPD-229 (14.33), CF10-1-10 (14.27) and CPD-307 (14.20). Number of seeds per pods is an important character for higher grain yield per plant in any pulse crop. CPD-305 (13.93) was show maximum seeds per pods followed by CF10-1-10 (13.27), CF4-1-4 (13.13) and RC-19 (13.00). High seed weight is desirable trait for high grain yield in cowpea genotypes CPD-229 (11.50g), CPD-307 (10.83g), CPD-330 (10.67g) and CPD-317(10.43g) were notice. These findings have also been reported by Verma *et al.* (2019), Owusu *et al.* (2021), Sheidu *et al.* (2023).

### Path Analysis

At genotypic level, were presented in table 4 and fig 1. The maximum positive direct effect of pod length (1.8451) was observed on grain yield per plant. Furthermore, branches per plant (1.7082), pods per cluster (0.3877), days to maturity (0.0930) and plant height (0.0872) also positive correlation with grain yield per plant and followed this trend in descending order. However, traits like days to maturity (-0.8076), seed weight (-0.6919), pods per plant (-0.5160) and seed per pod (-0.3142) showed negative direct effects irrespective of positive correlation with grain yield. At phenotypic level were presented in table 5 and fig 2. The maximum positive direct effect of seed per pod (0.5153) was observed on grain yield per plant. Furthermore, plant height (0.3568), days to 50% flowering (0.3209), branches per plant (0.2501), pod per cluster (0.1967) and seed weight (0.0498), followed this trend descending order which was earlier

said to be positively correlated with grain yield. However, traits like pod length (-0.3614), pods per plant (-0.0804) and days to maturity (-0.0414) showed negative direct effect irrespective of positive correlation with grain yield.

At genotypic level were days to maturity, plant height, and branches per plant, pods per cluster and pod length were show positive direct effect with grain yield per plant while, days to 50% flowering, pods per plant, seed per pod and 100-seed weight show negative direct effect with grain yield per plant. At phenotypic level, positive direct effect with grain yield per plant were observed days to 50 % flowering, plant height, branches per plant, pods per cluster, seed per pod and seed weight. While, days to maturity, pods per plant and pod length show negative direct effect with grain yield per plant. Similar result was found by Chopdar *et al.*, (2017), Dinesh *et al.* (2017), Walle *et al.* (2018), Agbeleye *et al.* (2020), Dhunde *et al.* (2021), Tirkey *et al.* (2022), Mohammad and Rashid (2022), Verma *et al.*, (2023), Assefa *et al.*, (2024) and Anita *et al.*, (2025)

### Residual effect

The residual effect at the genotypic level 0.21631 and phenotypic level 0.57848 was observed. This suggests that most of the characters made significant contributions towards the grain yield per plant.

**Table 2:** ANOVA for different characters in cowpea genotypes.

Characters	Mean Sum of Square		
	Replication (2df)	Genotypes (17df)	Error (34df)
Days 50% flowering	1.35	43.66**	20.11
Days to maturity	1.50	32.99**	16.46
Plant height (cm)	4.06	246.56**	5.34
Branches per plant	0.09	2.73**	0.68
Pods per plant	4.84	19.37**	4.91
Pods per cluster	0.37	0.66**	0.11
Pod length (cm)	2.96	5.35**	2.47
Seeds per pod	0.21	4.31**	2.04
Seed weight (g)	0.36	3.46**	0.26
Grain yield per plant (g)	0.82	4.10**	2.05

**Table 3:** Mean performance of yield and yield attributes of cowpea genotypes

S. No.	Genotypes	Days to 50% flowering	Days to maturity	Plant height (cm)	Branches per plant	Pods per plant	Pods per cluster	Pod length (cm)	Seeds per pod	Seed weight (g)	Grain yield per plant (g)
1.	CPD-229	45.33	69.33	50.45	7.67	13.27	2.27	14.33	11.67	11.50	12.20
2.	CPD-260	54.33	66.33	52.16	7.20	19.93	2.80	13.27	11.27	8.80	13.40
3.	CPD-269	51.33	67.33	49.96	7.07	13.67	2.17	13.93	12.47	9.57	13.40
4.	CPD-273	44.00	65.67	53.70	6.73	20.27	3.13	12.53	10.60	8.73	12.07

5.	CPD-302	46.33	66.67	54.91	8.27	16.87	2.67	11.80	9.27	8.87	12.33
6.	CPD-305	44.33	63.33	59.75	6.33	18.47	2.83	15.87	13.93	8.47	12.67
7.	CPD-307	46.67	69.00	56.62	7.47	21.27	2.20	14.20	12.13	10.83	13.73
8.	CPD-317	45.67	65.33	59.45	6.60	19.27	2.80	14.13	12.47	10.43	13.53
9.	CPD-330	44.67	70.00	37.32	7.47	20.67	3.07	13.27	11.80	10.67	11.20
10.	IC-0650821	45.00	59.67	39.41	9.53	21.80	4.00	11.60	12.40	8.10	14.00
11.	CF1-1-1	50.33	61.67	35.92	7.47	18.60	2.67	13.00	12.20	8.83	13.60
12.	CF2-1-2	45.67	65.33	35.81	7.33	17.73	3.33	12.73	11.87	8.43	13.33
13.	CF4-1-4	45.00	63.00	37.32	8.93	21.00	2.40	13.00	13.13	7.77	12.20
14.	CF9-1-9	42.67	58.67	38.12	5.47	14.93	2.13	13.53	11.87	8.80	10.07
15.	CF10-1-10	45.33	62.00	37.51	7.53	21.00	2.87	14.27	13.27	8.13	13.00
16.	RC-19(C)	54.00	66.33	37.60	6.73	19.73	2.53	13.67	13.00	8.57	12.00
17.	RC-101(C)	48.00	64.00	37.32	6.60	18.13	2.33	10.47	9.80	8.10	11.47
18.	TC-901(C)	54.67	69.33	40.14	6.47	19.00	2.60	15.67	10.80	8.70	10.20
	<b>Mean</b>	<b>47.41</b>	<b>65.17</b>	<b>45.19</b>	<b>7.27</b>	<b>18.64</b>	<b>2.71</b>	<b>13.40</b>	<b>11.89</b>	<b>9.07</b>	<b>12.47</b>
	S.Em	2.59	2.34	1.34	0.48	1.28	0.20	0.91	0.82	0.29	0.83
	C.D.(p=0.05)	7.44	6.73	3.84	1.38	3.68	0.57	2.61	2.37	0.85	2.38
	C.V. (%)	9.46	6.23	5.12	11.41	11.89	12.67	11.73	12.02	5.63	11.49

**Table 4:** Estimation of direct and indirect effect of different characters of cowpea on grain yield per plant at genotypic level

Characters	Days to 50% flowering	Days to maturity	Plant height (cm)	Branches per plant	Pods per plant	Pods per cluster	Pod length (cm)	Seeds per pod	Seed weight (g)	Correlation with grain yield per plant
Days 50% flowering	<b>-0.8076</b>	0.0816	-0.0141	-0.5247	0.0138	-0.1418	0.9413	0.0105	0.1112	-0.330*
Days to maturity	-0.7306	<b>0.0903</b>	0.0389	0.0213	0.0604	-0.1187	1.0257	0.1856	-0.6819	-0.109
Plant height (cm)	0.1310	0.0403	<b>0.0872</b>	-0.3086	0.0898	-0.062	0.7805	0.0277	-0.3205	0.465**
Branches per plant	0.2481	0.0011	-0.0157	<b>1.7082</b>	-0.231	0.2176	-1.2944	-0.0162	0.1083	0.726**
Pods per plant	0.0216	-0.0106	-0.0152	0.7648	<b>-0.5160</b>	0.2559	-0.3226	-0.0674	0.2485	0.359**
Pods per cluster	0.2954	-0.0276	-0.0139	0.959	-0.3405	<b>0.3877</b>	-1.0432	0.026	0.2085	0.451**
Pod length (cm)	-0.412	0.0502	0.0369	-1.1983	0.0902	-0.2192	<b>1.8451</b>	-0.1475	-0.3066	-0.261
Seeds per pod	0.0269	-0.0533	-0.0077	0.088	-0.1108	-0.032	0.8662	<b>-0.3142</b>	-0.0209	0.442**
100-seed weight (g)	0.1298	0.089	0.0404	-0.2673	0.1854	-0.1168	0.8177	-0.0095	<b>-0.6919</b>	0.177

**Table 5:** Estimation of direct and indirect effect of different characters of cowpea on grain yield per plant at phenotypic level

Characters	Days to 50% flowering	Days to maturity	Plant height (cm)	Branches per plant	Pods per plant	Pods per cluster	Pod length (cm)	Seeds per pod	Seed weight (g)	Correlation with grain yield per plant
Days 50% flowering	<b>0.3209</b>	-0.0027	-0.0174	-0.0048	-0.0010	-0.0179	0.0113	-0.0876	-0.0029	0.198
Days to maturity	0.0206	<b>-0.0414</b>	0.0920	-0.0293	0.0086	-0.0387	-0.0529	-0.0701	0.0191	-0.092
Plant height (cm)	-0.0156	-0.0107	<b>0.3568</b>	-0.0244	0.0064	-0.0166	-0.0876	-0.0131	0.0201	0.215
Branches per plant	-0.0062	0.0048	-0.0349	<b>0.2501</b>	-0.0209	0.0622	0.0575	0.0274	-0.0020	0.338*
Pods per plant	0.0038	0.0044	-0.0285	0.0649	<b>-0.0804</b>	0.0730	0.0237	0.0986	-0.0121	0.148
Pods per cluster	-0.0292	0.0081	-0.0301	0.0790	-0.0298	<b>0.1967</b>	0.0087	0.0970	-0.0139	0.286*
Pod length (cm)	-0.0100	-0.0061	0.0865	-0.0398	0.0053	-0.0047	<b>-0.3614</b>	0.3004	0.0108	-0.019
Seeds per pod	-0.0546	0.0056	-0.0091	0.0133	-0.0154	0.0370	-0.2107	<b>0.5153</b>	-0.0053	0.276*
Seed weight (g)	-0.0185	-0.0158	0.1443	-0.0099	0.0195	-0.0551	-0.0781	-0.0554	<b>0.0498</b>	-0.019

Residual effect=0.57848, Direct effect on main diagonal (bold figures) and \*, \*\* Significant at 5% and 1% probability levels

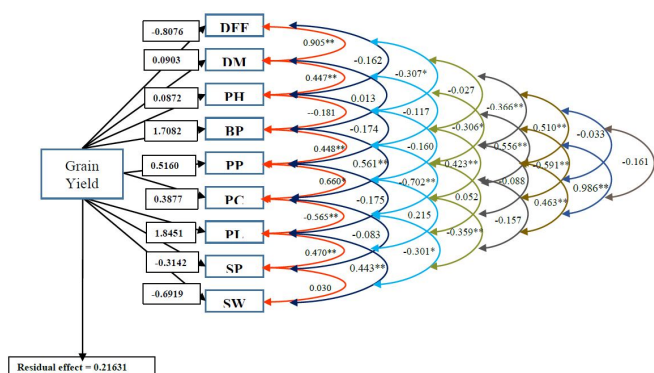

**DFF** = Days to 50% Flowering, **DM** = Days to Maturity, **PH** = Plant Height, **BP** = Branches per plant, **PP** = Pods per plant, **PC** = Pods per cluster, **PL** = Pod Length, **SP** = Seeds per pod, **SW** = Seed Weigh

**Fig. 1 :** Diagrammatic representation of genotypic path analysis different characters of cowpea

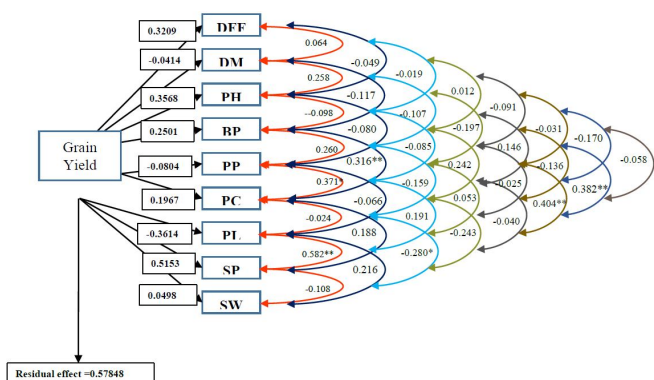

**DFF** = Days to 50% Flowering, **DM** = Days to Maturity, **PH** = Plant Height, **BP** = Branches per plant, **PP** = Pods per plant, **PC** = Pods per cluster, **PL** = Pod Length, **SP** = Seeds per pod, **SW** = Seed Weight

**Fig. 2. :** Diagrammatic representation of phenotypic path analysis different characters of cowpea

**Conclusion**

On the basis of average performance of various genotypes, it was revealed that among 18 genotypes of IC-0650821, CF1-1-1 and CPD-307 substantially displayed higher grain yield per plant. These genotypes were also found to be better for one or more yield component characters. Other genotypes like CPD-305 for pod length and plant height, CPD-229 for seed weight, CF9-1-9 and CPD-273 for early days to 50% flowering, CF9-1-9 and IC-0650821 for early maturity. IC-0650821 for branches per plant, pods per plant, pods per cluster and CPD-305 for seed per plant were highest recorded were found be superior, so accordingly these genotypes may be used in future breeding programme. The characteristics, such as the duration to reach 50% flowering, plant height, number of branches per plant, pods per cluster, total pods per plant, seeds per pod, and seed weight, displayed a positive and direct influence on the grain yield per plant and also demonstrated a positive correlation with grain yield per plant. Therefore, making selections

based on these traits will lead to the development of high-performing superior cowpea genotypes.

**References**

Agbeleye, O. A., Akinyosoye, S. T., and Adetumbi, J. A., 2020. Correlation, Path Coefficient and Principal Component Analysis of Yield Components in Mung bean [*Vigna radiata* (L.) Wilcezk] Accessions. *Tropical Agriculture*, **97**(4).

Ahmad, S. and Belwal, V. 2020. Study of Correlation and Path Analysis for Yield and Yield Attributing Traits in Mungbean [*Vigna radiata* (L.) Wilcezk]. *International Journal of Chemical Studies*, **8**(1), 2140-2143.

Anita, S. R., Kumar, A., and Suchitra, A. K., 2025. Correlation and Path Analysis Studies of Pod Yield and its Component Traits in Mungbean [*Vigna radiata* (L.) Wilcezk] Genotypes. *Legume Research-An International Journal*, **1**, 6.

Anonymous, 2023a. Package of Practices of Cowpea, Directorate of Pulse Development. (<https://dpd.gov.in/Cowpea.pdf>)

Anonymous, 2024. Rajasthan Agricultural Statistics at a Glance. Commissionerate of Agriculture, Jaipur, Rajasthan.

Assefa, A., Mekonnen, D., and Bantayehu, M., 2024. Path Coefficient, Genetic Divergent and Principal Component Analysis on Common Bean (*Phaseolus Vulgaris* L.) Genotypes in Sekota, North Western Ethiopia. *International Journal on Food, Agriculture and Natural Resources*, **5**(4), 105-113.

Bizeti, H. S., De Carvalho, C.G.P., De Souza, J.R.P., and Destro D., 2004. Path Analysis under Multicollinearity in Soyabean. *Agronomy Journal*, **47**, 669-676.

Chaudhary, R. R. and Joshi, B. K. 2005. Correlation and Path Coefficient Analysis in Sugarcane, *Nepal Agriculture Research Journal*, **6**, 24-28.

Chopdar, D. K., Bharti, B. Sharma, P. P., Dubey, R. B., and Meena, B. L., 2017. Studies on Genetic Variability, Character Association and Path Analysis for Yield and its Contributing Traits in Chickpea [*Cicer arietinum* (L.)]. *Legume Research-An International Journal*, **40**(5), 824-829.

Dewey, D. R. and Lu, K. 1959. A Correlation and Path-Coefficient Analysis of Components of Crested Wheat Grass Seed Production. *Agronomy Journal*, **51**(9), 515-518.

Dhunde, B. B., Devmore, J. P., Mahadik, S. G., Palshetkar, M. G., Vanve, P. B., Bhave, S. G., and Thorat, B. S., 2021. Correlation and Path Analysis Studies on Yield and its Components in Green gram [*Vigna radiata* L. Wilcezk]. *The Pharma Innovation Journal*, **10**(1), 727-30.

Dinesh, H. B., Viswanatha, K. P., Lohithaswa, H. C., Pavan, R., and Poonam, S., 2017. Variability, Correlation and Path Analysis Studies in F3 Generation of Cowpea [*Vigna unguiculata* (L.) Walp]. *International Journal of Current Microbiology and Applied Sciences*, **6**, 1420-1428.

Hulsure, P., Thomas, B., Arya, K., Gayathri, G., Nair, A. S., and Varanya, A., 2022. Genetic Analysis in Grain Cowpea [*Vigna unguiculata* (L.) Walp] for Yield and Quality. *The Pharma Innovation Journal*, **11**(3), 2394- 2398.

- Kiran, S. B. 2020. Genetic Divergence Studies in Cowpea (*Vigna unguiculata* L. Walp.) *Journal of Pharmacognosy and Phytochemistry*, **9**(5), 2839-2845.
- Mohammad, M. T. and Rashid, H. H. 2022. Correlation Coefficient and Path Analysis of yield and its components for Seven Cowpea Genotypes (*Vigna unguiculata* L.) and its F<sub>1</sub> Hybrids. *Tikrit Journal for Agricultural Sciences*, **23**(4), 1-12.
- Owusu, E. Y., Karikari, B., Kusi, F., Haruna, M., Amoah, R. A., Attamah, P., and Issahaku, M., 2021. Genetic Variability, Heritability and Correlation Analysis among Maturity and Yield Traits in Cowpea [*Vigna unguiculata* (L) Walp] in Northern Ghana. *Heliyon*, **7**(9), 2405-8440.
- Panse, V. G. and Sukhatme, P. V. 1985. Statistical Methods for Agricultural Workers. *Indian Council of Agricultural Research Publication*, 87-89.
- Sheidu, A., Shammah, A. M., and Jibrin, I. M., 2023. Genetic Variability, Heritability and Genetic Advance of Improved Cowpea Genotypes (*Vigna unguiculata* L.). *Fundamental Journal of Science*, **7**(3), 297-301.
- Singh, D. P., Jain, M., and Goyal, M., 2022. Assessment of Variability and Association Analysis for Forage Traits in Cowpea (*Vigna unguiculata* (L). Walp). *Forage Research*, **48**(3), 315-319
- Tirkey, M., Lal, G. M., and Anand, S. P., 2022. Estimation of Correlation and Path Analysis for Quantitative Traits in Cowpea (*Vigna unguiculata* (L.) Walp). *International Journal of Plant and Soil Science (IJPSS)*, **34**(22), 1194-1200.
- Verma, A. K., Mehta, A. K., Gontia, A. S., Sharma, D., Singh, R. P., and Singh, P., 2019. Genetic Variability, Heritability and Genetic Advance Studies for Yield Components in F<sub>2</sub> Generation of Cowpea [*Vigna unguiculata* (L.) Walp]. *International Journal of Chemical Studies*, **7**(6), 3084.
- Verma, K. C., Singh, H., Meena, R., Khan, M., Attar, S. K., Khatik, C. L. and Dhaka, S. R., 2023. Correlation Coefficient and Path Analysis between Grain Yield and Growth Parameters, Weed and Yield Attributes of Cowpea (*Vigna unguiculata* L.) as Influenced by Weed Management Practices under Rainfed Condition. *The Pharma Innovation Journal*, **12**(6), 2142-2146.
- Walle, T., Mekbib, F., Amsalu, B., and Gedil, M., 2018. Correlation and Path Coefficient Analyses of Cowpea (*Vigna unguiculata* L.) Landraces in Ethiopia. *American Journal of Plant Sciences*, **9**, 2794-2812.
- Wright, S. 1921. Correlation and Causation. *Journal of Agricultural Research*, **20**, 25-28.